

**NOTE:** ENSURE THAT THE POWER TO THE FIXTURE'S CIRCUIT IS TURNED OFF. | **NOTE:** VOUS ASSUREZ QUE L'ALIMENTATION DU CIRCUIT AU LUMINAIRE EST COUPÉE AU CIRCUIT.

**CAUTION: To reduce the risk of fire, use only luminaire assemblies from Axis Lighting, class 2, 48VDC**

**ATTENTION: Pour réduire les risques d'incendie, utilisez uniquement des ensembles de luminaires d'Éclairage Axis. Classe 2, 48VDC**

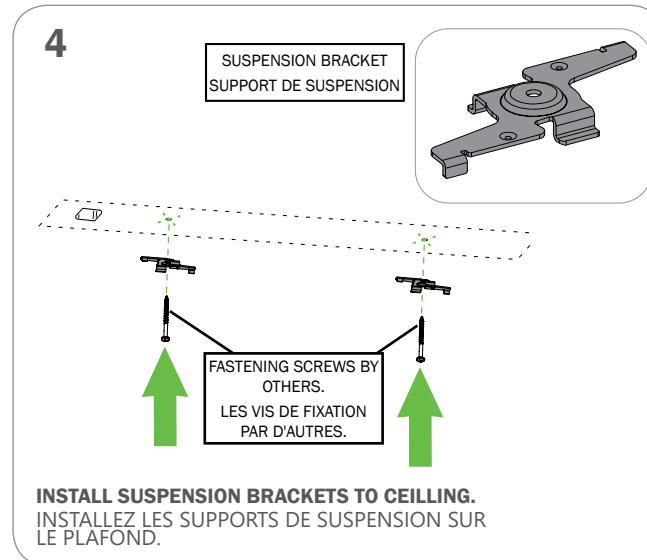
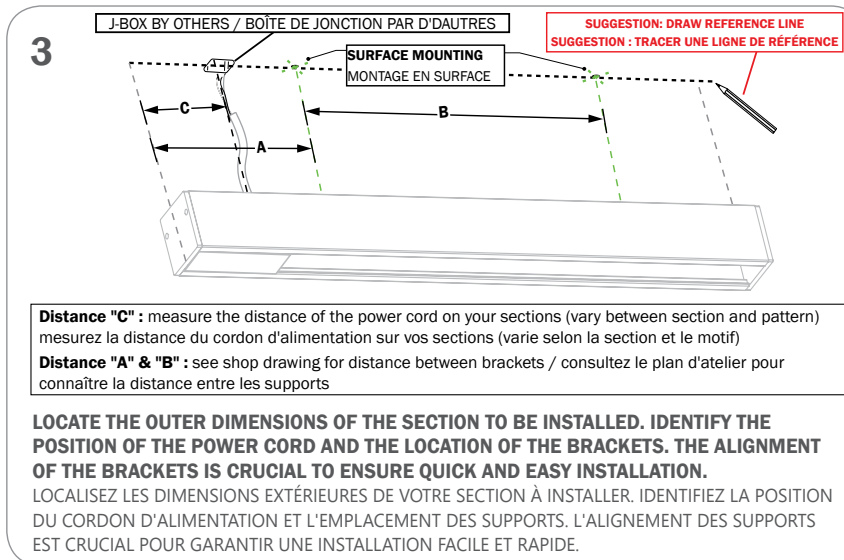
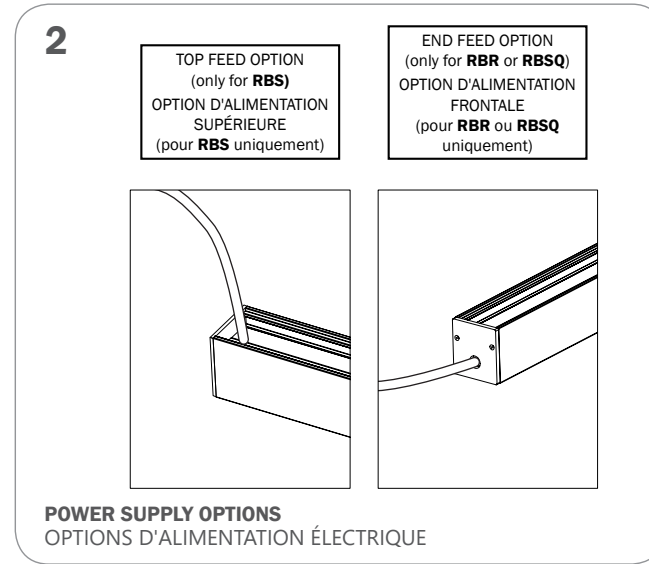
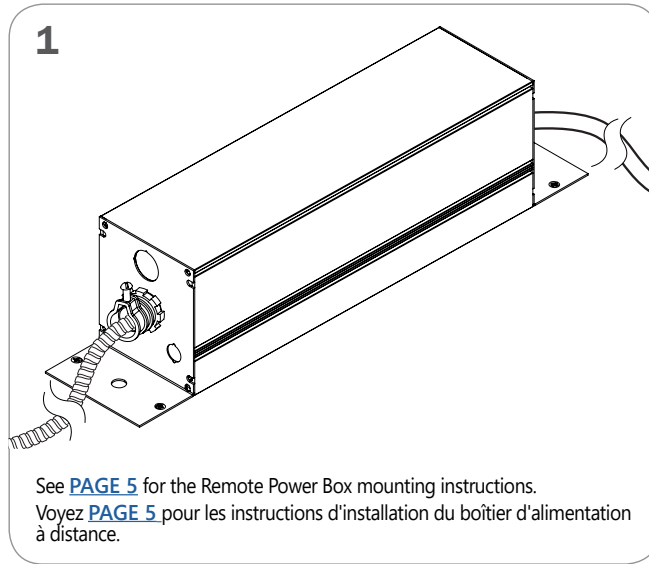

**NOTE:** ENSURE THAT THE POWER TO THE FIXTURE'S CIRCUIT IS TURNED OFF. | **NOTE:** VOUS ASSUREZ QUE L'ALIMENTATION DU CIRCUIT AU LUMINAIRE EST COUPÉE AU CIRCUIT.

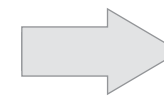
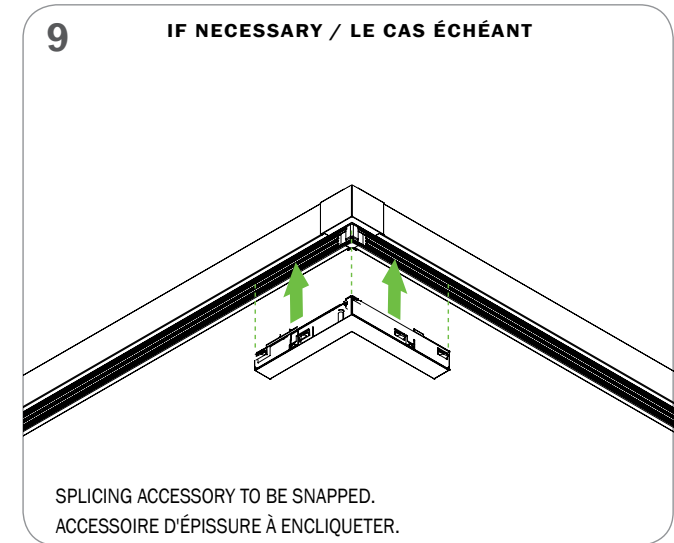
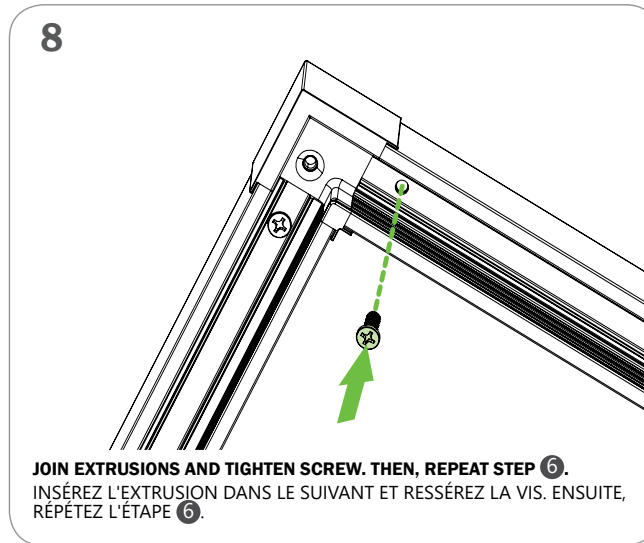
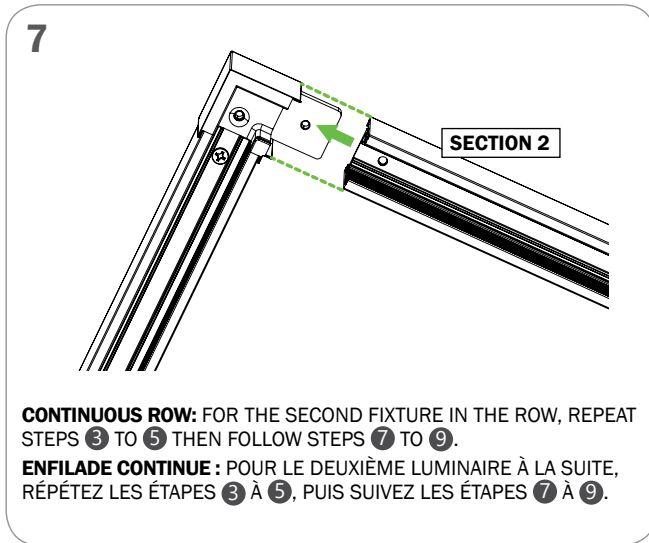
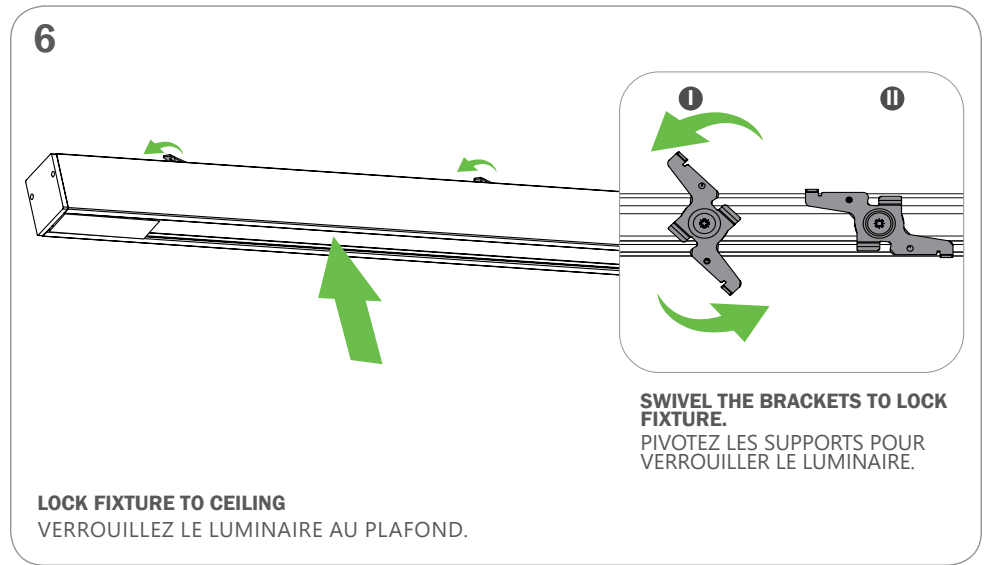
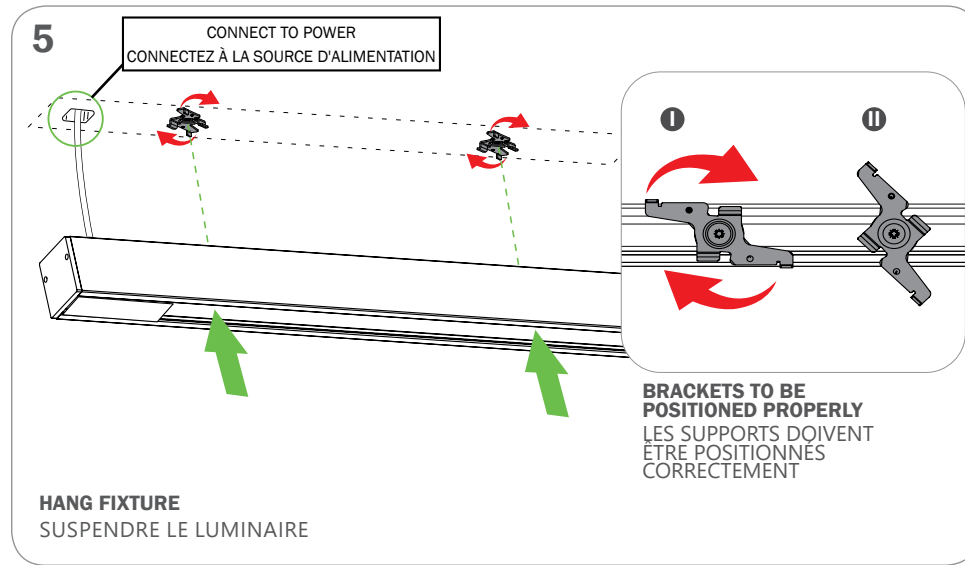

**Please see next page for ACCESSORY options.**  
**Veillez consulter la page suivante pour les options d'ACCESSOIRES.**

Product design and development is an ongoing process at Axis Lighting. We reserve the right to change specifications. Contact Axis for the latest product information. © 2018 Axis Lighting Inc. 1.800.263.2947 [T]514.948.6272

La conception et le développement font partie d'un processus d'évolution continu chez Éclairage Axis. Nous nous réservons le droit de changer les spécifications. Pour obtenir l'information la plus récente sur le produit, veuillez contacter Axis.

FILE NAME / NOM DE FILIÈRE :THDS\_RBS.INST\_1-2026  
REVISION 001 / RÉVISION 001

8 / 01 / 2026



**WARNING :** LOCATE ALL POWER CONDUITS AND CABLES. **RISK OF FIRE AND ELECTRICAL SHOCK. FIXTURE MUST BE INSTALLED BY A QUALIFIED ELECTRICIAN ONLY IN ACCORDANCE WITH NATIONAL, LOCAL BUILDING AND ELECTRICAL CODES. DISCONNECT POWER AT ELECTRICAL PANEL BEFORE SERVICING.**

**AVERTISSEMENT :** LOCALISER TOUS LES CIRCUITS ET CABLES. **RISQUE D'INCENDIE ET DE CHOC ÉLECTRIQUE. LE LUMINAIRE DOIT ÊTRE INSTALLÉ PAR UN ÉLECTRICIEN QUALIFIÉ ET EN RESPECTANT LES CODES DU BÂTIMENT ET ÉLECTRIQUES NATIONAUX ET LOCAUX. COUPER L'ALIMENTATION AU PANNEAU ÉLECTRIQUE AVANT D'EFFECTUER L'ENTRETIEN.**

**NOTE:** ENSURE THAT THE POWER TO THE FIXTURE'S CIRCUIT IS TURNED OFF. | **NOTE:** VOUS ASSUREZ QUE L'ALIMENTATION DU CIRCUIT AU LUMINAIRE EST COUPÉE AU CIRCUIT.

**CAUTION: To reduce the risk of fire, use only luminaire assemblies from Axis Lighting, class 2, 48VDC**  
**ATTENTION: Pour réduire les risques d'incendie, utilisez uniquement des ensembles de luminaires d'Éclairage Axis. Classe 2, 48VDC**

#### INSTALLATION ONTO TRACK / INSTALLATION SUR RAIL

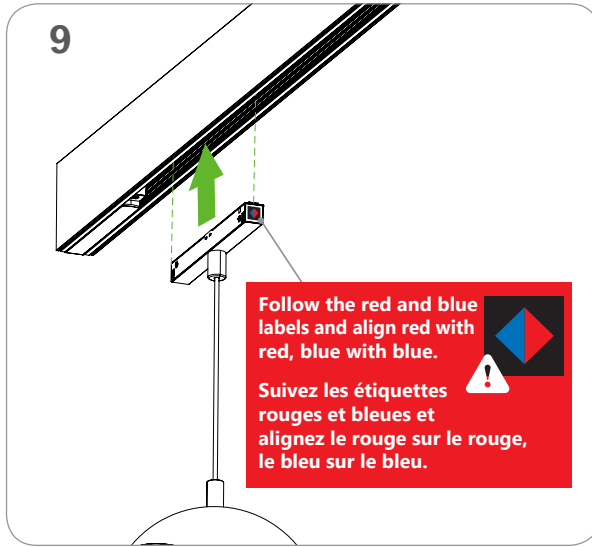

MAGNETIC ATTACHMENT TO TRACK  
FIXATION MAGNÉTIQUE AU RAIL

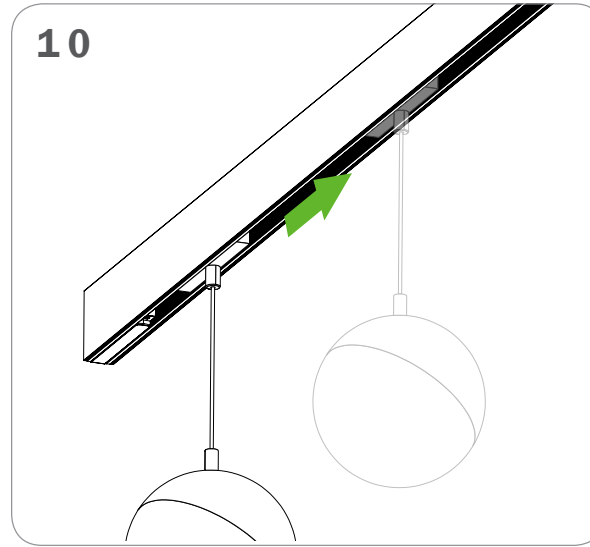

SLIDE ALONG TRACK TO CHANGE POSITION  
GLISSER LE LONG DU RAIL POUR CHANGER DE POSITION

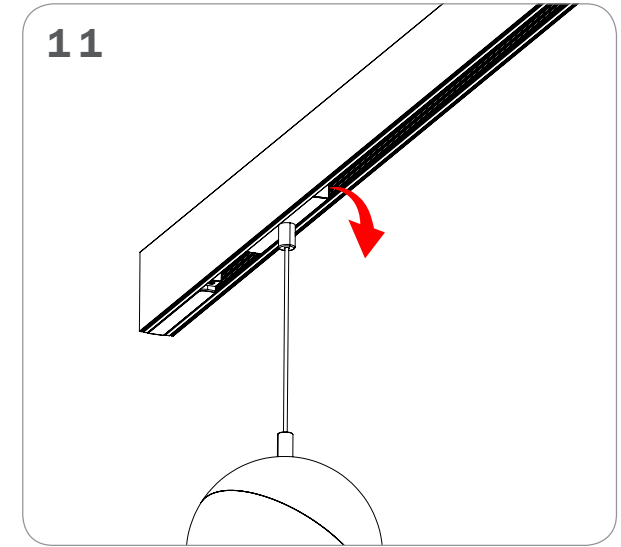

PIVOT ON ONE SIDE TO REMOVE FROM TRACK  
PIVOTER SUR UN CÔTÉ POUR RETIRER DU RAIL

#### APPLIES TO FOLLOWING PARTS / S'APPLIQUE AUX PIÈCES SUIVANTES

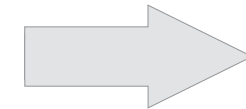

**continue next page**  
**continuez à la page suivante**



**NOTE:** ENSURE THAT THE POWER TO THE FIXTURE'S CIRCUIT IS TURNED OFF. | **NOTE:** VOUS ASSUREZ QUE L'ALIMENTATION DU CIRCUIT AU LUMINAIRE EST COUPÉE AU CIRCUIT.

**CAUTION: To reduce the risk of fire, use only luminaire assemblies from Axis Lighting, class 2, 48VDC**  
**ATTENTION: Pour réduire les risques d'incendie, utilisez uniquement des ensembles de luminaires d'Éclairage Axis. Classe 2, 48VDC**

### INSTALLATION ONTO AXISTRAK™ / INSTALLATION SUR L' AXISTRAK™

### APPLIES TO FOLLOWING PARTS / S'APPLIQUE AUX PIÈCES SUIVANTES

CHYME TAPERS - 18", 24" AND 36"

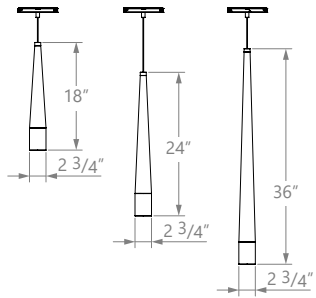

ORBIT TUBES - PIVOT, BRIDGE AND STAGGER



CONSTELLATION PROJECTOR

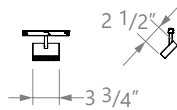

HELIOS DISK

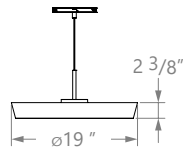

CHYME CYLLINDERS

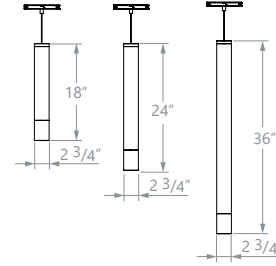

LUNAS - STRAIGHT AND PIVOTED, AND PENDANT, FLUSH AND SATTLE

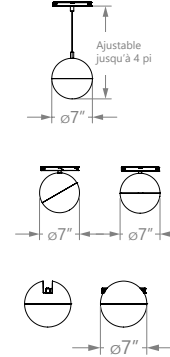

STELLA 32, DUO AND STELLA 55

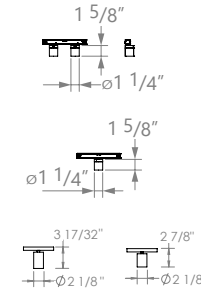

CYLINDER 55 AND 100

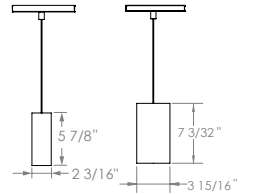

FRAMING PROJECTOR

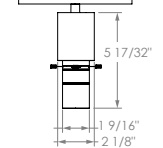

TRACK DECORATIVE DIRECT LINEAR

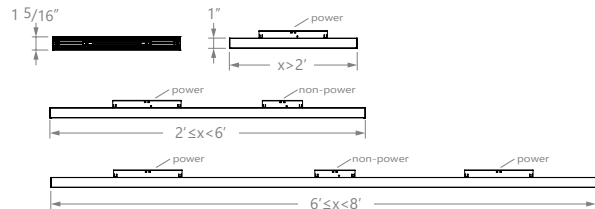

FLEXIBLE INTEGRATED MODULE

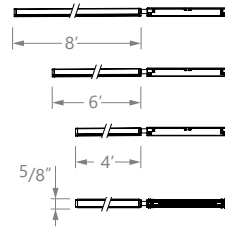

FLEXIBLE 360° TUBE

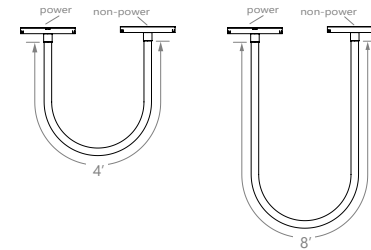

MIKROLITE

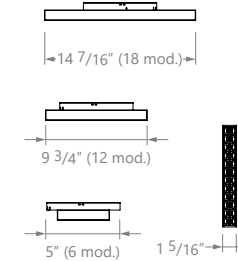

INDIRECT INSERT

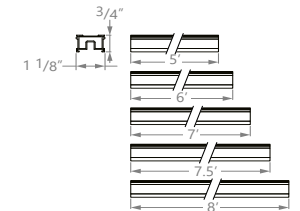

ROUND INDIRECT LIGHT

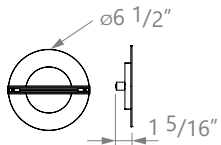

FROSTED GLASS ORB

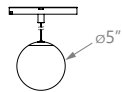

FLUSH FROSTED GLASS ORB

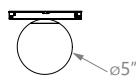

PENDANT LAMP SHADES :

BIG BELL

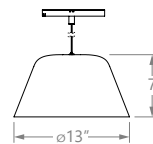

SMALL BELL

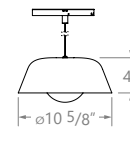

BIG CONE

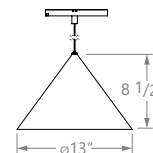

SMALL CONE

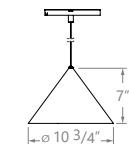

BIG DOME

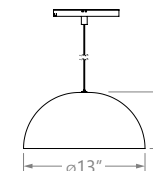

SMALL DOME

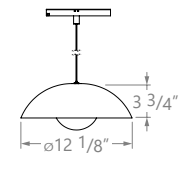

Product design and development is an ongoing process at Axis Lighting. We reserve the right to change specifications. Contact Axis for the latest product information. © 2018 Axis Lighting Inc. 1.800.263.2947 [T]514.948.6272

La conception et le développement font partie d'un processus d'évolution continu chez Éclairage Axis. Nous nous réservons le droit de changer les spécifications. Pour obtenir l'information la plus récente sur le produit, veuillez contacter Axis.

FILE NAME / NOM DE FILIÈRE :THDS\_RBS.INST\_1-2026  
 REVISION 001 / RÉVISION 001

8 / 01 / 2026



**W A R N I N G :** LOCATE ALL POWER CONDUITS AND CABLES. **RISK OF FIRE AND ELECTRICAL SHOCK. FIXTURE MUST BE INSTALLED BY A QUALIFIED ELECTRICIAN ONLY IN ACCORDANCE WITH NATIONAL, LOCAL BUILDING AND ELECTRICAL CODES. DISCONNECT POWER AT ELECTRICAL PANEL BEFORE SERVICING.**

**A V E R T I S S E M E N T :** LOCALISER TOUS LES CIRCUITS ET CABLES. **RISQUE D'INCENDIE ET DE CHOC ÉLECTRIQUE. LE LUMINAIRE DOIT ÊTRE INSTALLÉ PAR UN ÉLECTRICIEN QUALIFIÉ ET EN RESPECTANT LES CODES DU BÂTIMENT ET ÉLECTRIQUES NATIONAUX ET LOCAUX. COUPER L'ALIMENTATION AU PANNEAU ÉLECTRIQUE AVANT D'EFFECTUER L'ENTRETIEN.**

**NOTE:** ENSURE THAT THE POWER TO THE FIXTURE'S CIRCUIT IS TURNED OFF. | **NOTE:** VOUS ASSUREZ QUE L'ALIMENTATION DU CIRCUIT AU LUMINAIRE EST COUPÉE AU CIRCUIT.

**CAUTION:** To reduce the risk of fire, use only luminaire assemblies from Axis Lighting, class 2, 48VDC

**ATTENTION:** Pour réduire les risques d'incendie, utilisez uniquement des ensembles de luminaires d'Éclairage Axis. Classe 2, 48VDC

### REMOTE DRIVER BOX INSTALLATION INSTRUCTIONS / DIRECTIVES D'INSTALLATION DU BOÎTIER DE PILOTE À DISTANCE

#### 1 THD RBS

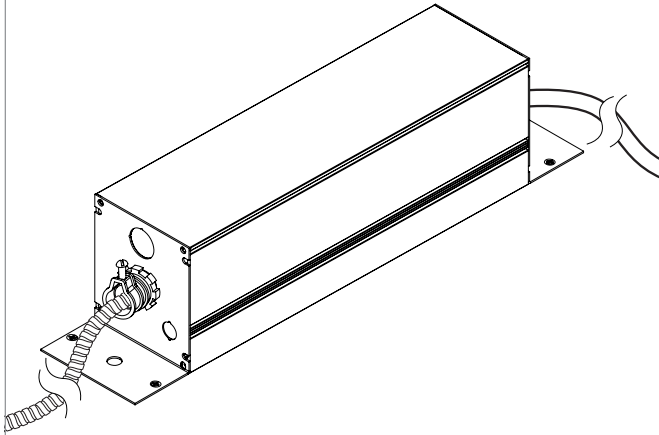

#### 2

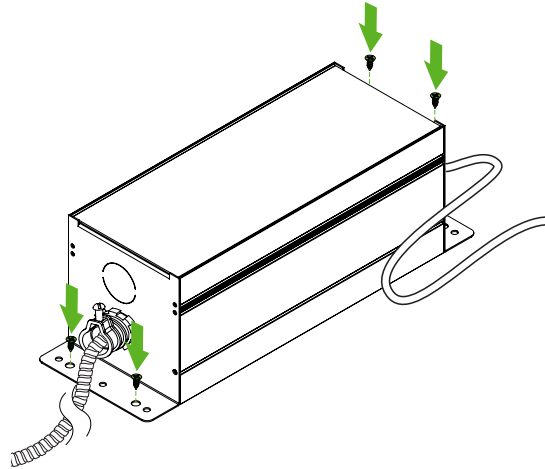

INSTALL BOX ON WALL WITH SCREWS (NOT SUPPLIED)  
INSTALLER LA BOÎTE SUR LE MUR AVEC DES VIS (NON FOURNIES)

#### 3

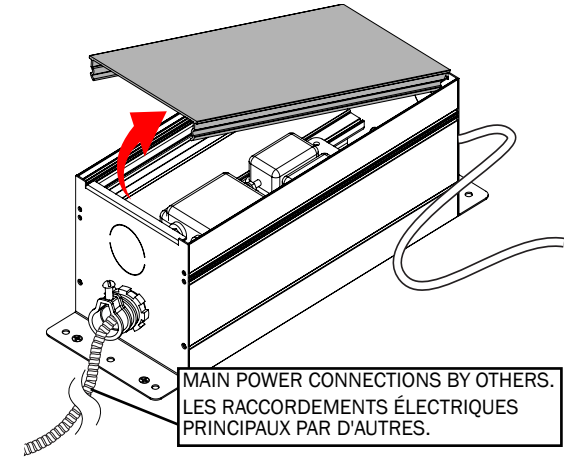

MAIN POWER CONNECTIONS BY OTHERS.  
LES RACCORDEMENTS ÉLECTRIQUES PRINCIPAUX PAR D'AUTRES.

REMOVE SNAP-IN ACCESS COVER TO ACCESS BOX INTERIOR  
RETIREZ LE COUVERCLE D'ACCÈS ENCLIQUETABLE POUR ACCÉDER À L'INTÉRIEUR DU BOÎTIER

#### 4

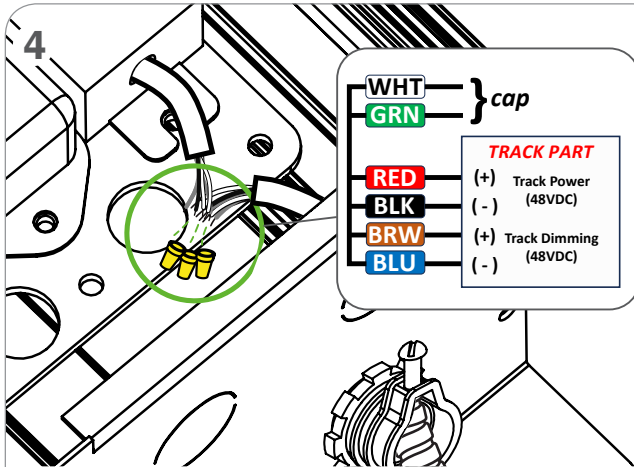

MAKE NECESSARY INTERNAL WIRING CONNECTIONS FOLLOWING THE WIRING DIAGRAM.  
EFFECTUEZ LES CONNEXIONS INTERNES NÉCESSAIRES EN SUIVANT LE SCHÉMA DE CÂBLAGE.

#### 5

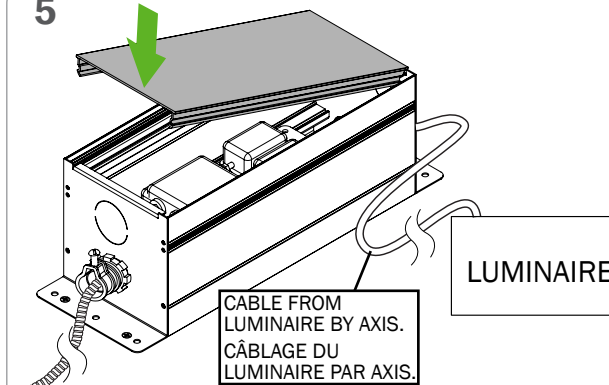

MAKE NECESSARY POWER CONNECTIONS TO FIXTURE PRIOR TO CLOSING THE BOX.  
EFFECTUEZ LES BRANCHEMENTS ÉLECTRIQUES NÉCESSAIRES AU LUMINAIRE AVANT DE FERMER LE BOÎTIER.

